



■ Features :

- Universal AC input/Full range
- ZVS new technology
- AC input active surge current limiting
- Built-in active PFC function,PF>0.95
- Protections: Short circuit / Overload / Over voltage / Over temperature
- Forced air cooling by built-in DC ball bearing fan
- High power density 8.3W/inch³
- Output voltage can be trimmed between 20% ~ 110% rated value
- Current sharing up to 4500W(2+1)
- Alarm signal output
- Built-in 12V/0.1A auxiliary output for remote control
- Built-in remote ON-OFF control
- Built-in remote sense function
- 3 years warranty



SPECIFICATION

MODEL		SPV-1500-12	SPV-1500-24	SPV-1500-48
OUTPUT	DC VOLTAGE	12V	24V	48V
	RATED CURRENT	125A	63A	32A
	CURRENT RANGE	0 ~ 125A	0 ~ 63A	0 ~ 32A
	RATED POWER	1500W	1512W	1536W
	RIPPLE & NOISE (max.) Note.2	150mVp-p	150mVp-p	200mVp-p
	VOLTAGE ADJ. RANGE	±5% typical adjustment by VR, 20% ~ 110% (typ.) adjustment by 1~6VDC external control signal		
	VOLTAGE TOLERANCE Note.3	±1.0%		
	LINE REGULATION	±0.5%		
	LOAD REGULATION	±0.5%		
	SETUP, RISE TIME	1500ms, 100ms at full load		
HOLD UP TIME (Typ.)	10ms at full load	14ms at full load	16ms at full load	
INPUT	VOLTAGE RANGE Note.5	90 ~ 264VAC	127 ~ 370VDC	
	FREQUENCY RANGE	47 ~ 63Hz		
	POWER FACTOR (Typ.)	0.95/230VAC	0.98/115VAC at full load	
	EFFICIENCY (Typ.)	86.5%	90%	90%
	AC CURRENT (Typ.)	17A/115VAC	8A/230VAC	
	INRUSH CURRENT (Typ.)	30A/115VAC	60A/230VAC	
	LEAKAGE CURRENT	<2.0mA / 240VAC		
PROTECTION	OVERLOAD	105 ~ 135% rated output power Protection type : Constant current limiting, recovers automatically after fault condition is removed		
	OVER VOLTAGE	13.8 ~ 16.8V	30 ~ 34.8V	57.6 ~ 67.2V
	OVER TEMPERATURE	105°C ±5°C (TSW2) detect on heatsink of power transistor		
		Protection type : Shut down o/p voltage, recovers automatically after temperature goes down		
FUNCTION	AUXILIARY POWER(AUX)	12V@0.1A(Only for Remote ON/OFF control)		
	REMOTE ON/OFF CONTROL	Please see the Function Manual		
	ALARM SIGNAL OUTPUT	Please see the Function Manual		
	OUTPUT VOLTAGE TRIM	2.4 ~ 13.2V	4.8 ~ 28V	9.6 ~ 56V
ENVIRONMENT	WORKING TEMP.	-20 ~ +70°C (Refer to "Derating Curve")		
	WORKING HUMIDITY	20~90% RH non-condensing		
	STORAGE TEMP., HUMIDITY	-40 ~ +85°C, 10 ~ 95% RH		
	TEMP. COEFFICIENT	±0.05%/°C (0 ~ 50°C)		
	VIBRATION	10 ~ 500Hz, 2G 10min./1cycle, 60min. each along X, Y, Z axes		
SAFETY & EMC (Note 4)	SAFETY STANDARDS	UL60950-1, TUV EN60950-1 approved		
	WITHSTAND VOLTAGE	I/P-O/P:3KVAC I/P-FG:1.5KVAC O/P-FG:0.5KVAC		
	ISOLATION RESISTANCE	I/P-O/P, I/P-FG, O/P-FG:100M Ohms / 500VDC / 25°C / 70% RH		
	EMC EMISSION	Compliance to EN55022 (CISPR22), EN61000-3-2,-3		
	EMC IMMUNITY	Compliance to EN61000-4-2,3,4,5,6,8,11, EN55024, light industry level, criteria A		
OTHERS	MTBF	109K hrs min. MIL-HDBK-217F (25°C)		
	DIMENSION	278*127*83.5mm (L*W*H)		
	PACKING	3.0Kg; 4pcs/13Kg/1.19CUFT		
NOTE	<ol style="list-style-type: none"> 1. All parameters NOT specially mentioned are measured at 230VAC input, rated load and 25°C of ambient temperature. 2. Ripple & noise are measured at 20MHz of bandwidth by using a 12" twisted pair-wire terminated with a 0.1uf & 47uf parallel capacitor. 3. Tolerance : includes set up tolerance, line regulation and load regulation. 4. The power supply is considered a component which will be installed into a final equipment. The final equipment must be re-confirmed that it still meets EMC directives. For guidance on how to perform these EMC tests, please refer to "EMI testing of component power supplies." (as available on http://www.meanwell.com) 5. Derating may be needed under low input voltages. Please check the derating curve for more details. 			

Mechanical Specification

Case No.943A Unit:mm

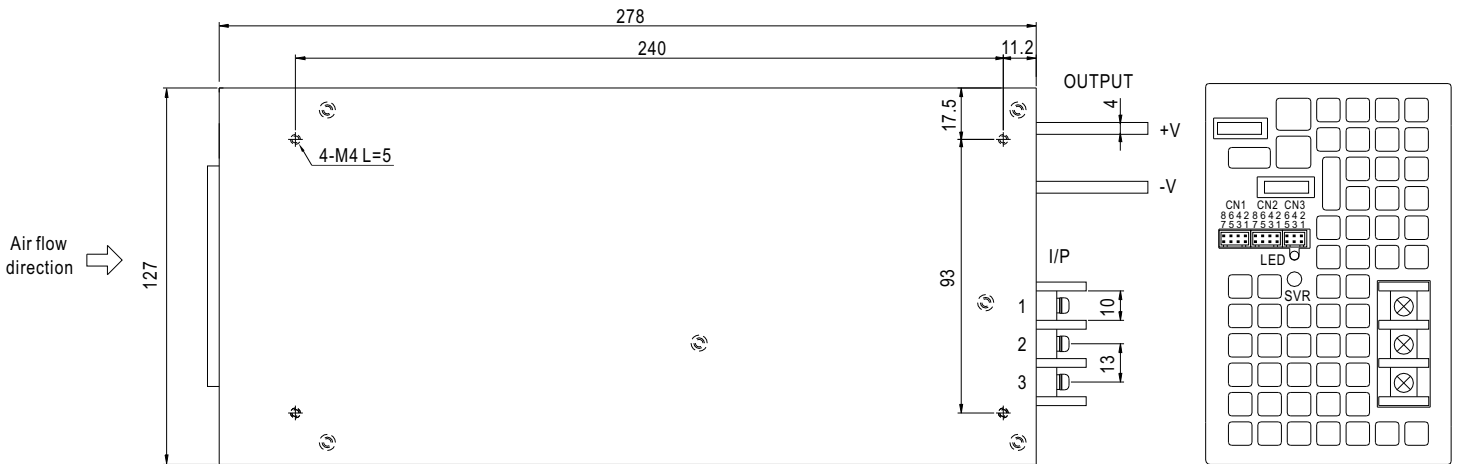
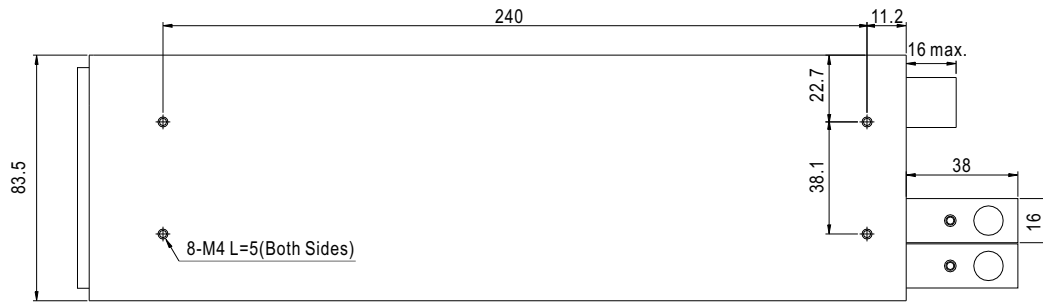

AC Input Terminal Pin No. Assignment

Pin No.	Assignment
1	FG \perp
2	AC/N
3	AC/L

Control Pin No. Assignment(CN1,CN2) : HRS DF11-8DP-2DS or equivalent

Pin No.	Assignment	Pin No.	Assignment	Mating Housing	Terminal
1	RCG	5,7	-S	HRS DF11-8DS or equivalent	HRS DF11-**SC or equivalent
2	RC2	6	LS(Current Share)		
3	PV	8	+S		
4	PS				

RCG: Remote ON/OFF Ground -S: -Remote Sensing
 RC2: Remote ON/OFF LS: Load Share
 PV: Output voltage external control +S: +Remote Sensing
 PS: Reference voltage terminal, PS and PV are connected when shipping

Control Pin No. Assignment(CN3) : HRS DF11-6DP-2DS or equivalent

Pin No.	Assignment	Pin No.	Assignment	Mating Housing	Terminal
1	P OK GND	4	AUXG	HRS DF11-6DS or equivalent	HRS DF11-**SC or equivalent
2	P OK	5	RC1		
3	RCG	6	AUX		

P OK GND: Power OK Ground AUXG: Auxiliary Ground
 P OK: Power OK Signal RC1: Remote ON/OFF
 RCG: Remote ON/OFF Ground AUX: Auxiliary Output

Block Diagram

PFC fosc : 70KHz
 PWM fosc : 100KHz

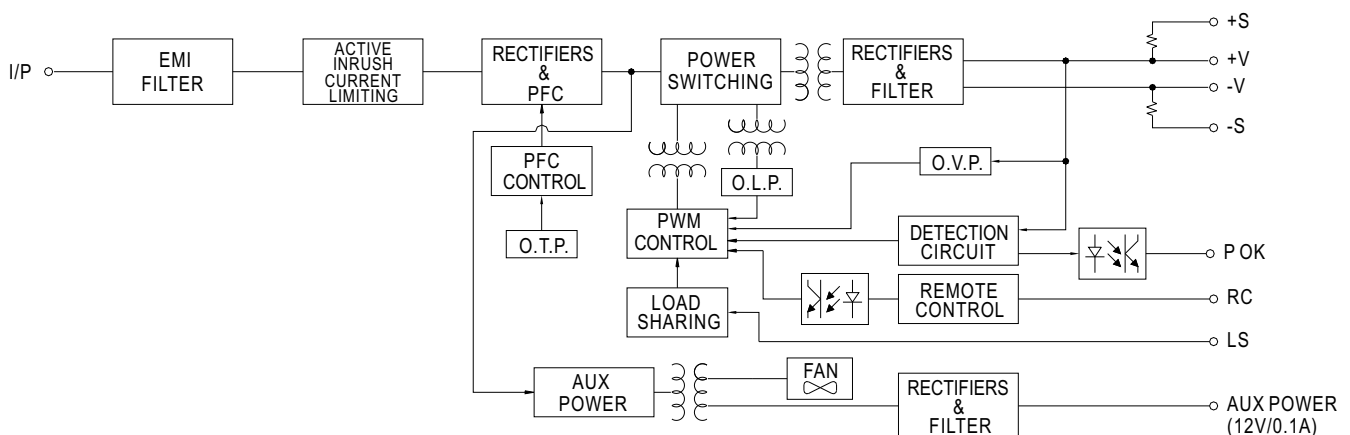

Derating Curve

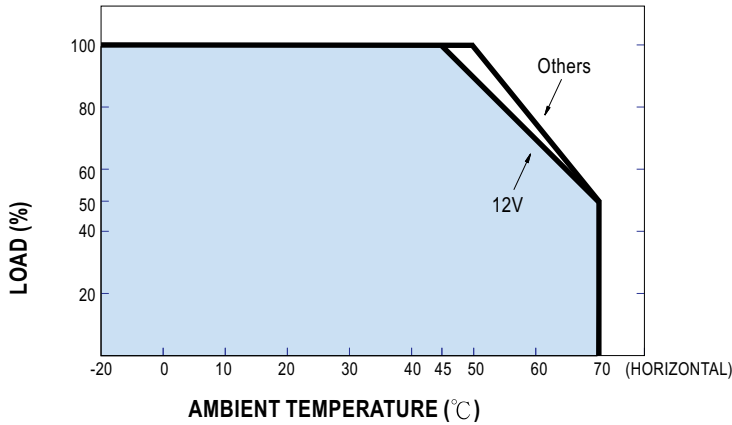

Static Characteristics

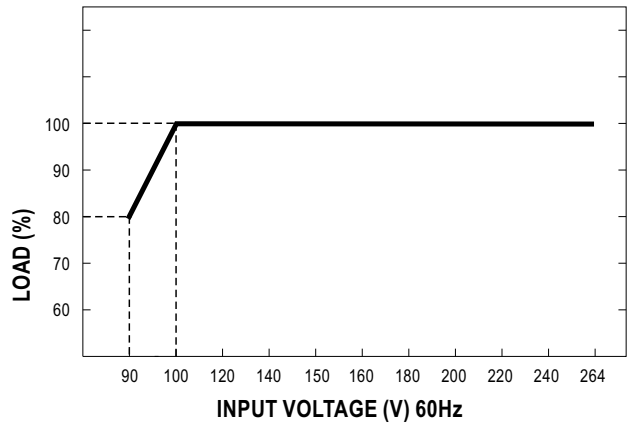

Function Manual

1. Remote ON/OFF

- (1) Remote ON/OFF control becomes available by applying voltage in CN1 & CN2 & CN3
- (2) Table 1.1 shows the specification of Remote ON/OFF function
- (3) Fig.1.2 shows the example to connect Remote ON/OFF control function

Table 1.1 Specification of Remote ON/OFF

Connection Method		Fig. 1.2(A)	Fig. 1.2(B)	Fig. 1.2(C)
SW Logic	Output on	SW Open	SW Open	SW Close
	Output off	SW Close	SW Close	SW Open

Fig.1.2 Examples of connecting remote ON/OFF

(A) Using external voltage source

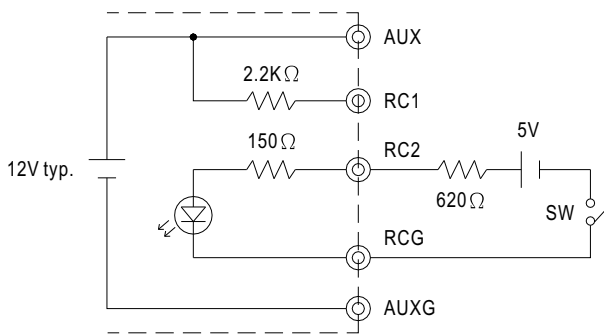

(B) Using internal 12V auxiliary output

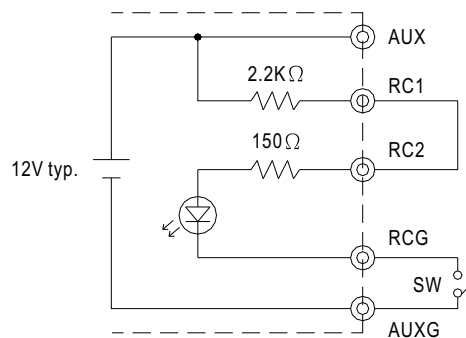

(C) Using internal 12V auxiliary output

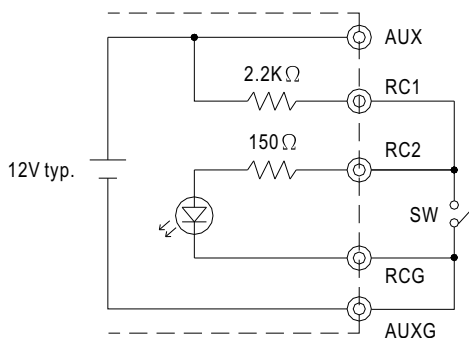

2. Alarm Signal Output

- Alarm signal is sent out through "P OK" & "P OK GND" pins
- An external voltage source is required for this function. The maximum applied voltage is 50V and the maximum sink current is 10mA
- Table 2.1 explains the alarm function built-in the power supply

Function	Description	Output of alarm(P OK)
P OK	The signal is "Low" when the power supply is above 15% of the rated output voltage-Power OK	Low (0.5V max at 10mA)
	The signal turns to be "High" when the power supply is under 15% of the rated output voltage-Power Fail	High or open (External applied voltage 10mA max.)

Table 2.1 Explanation of alarm function

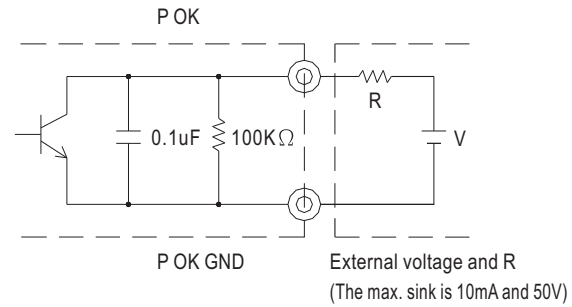
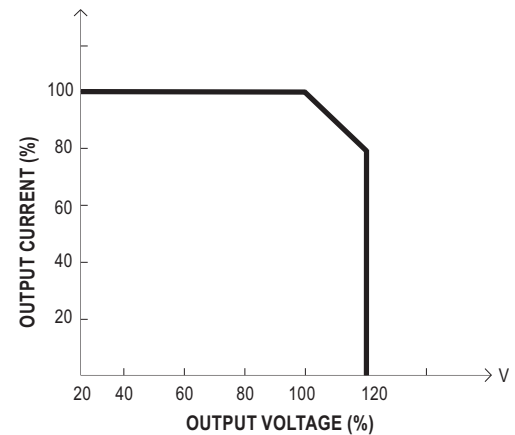
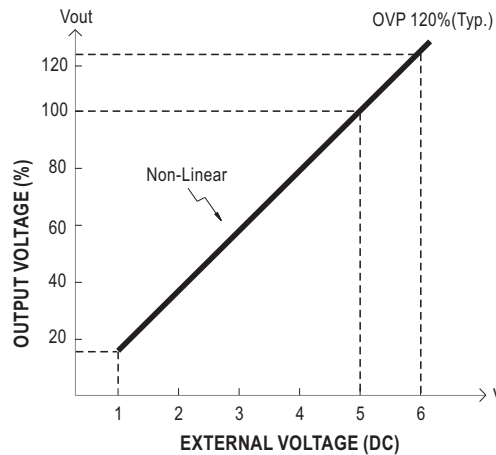
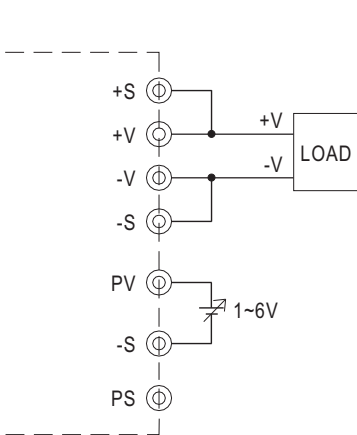

Fig. 2.2 Internal circuit of P OK (Open collector method)

3. External Voltage Control



- Note: (1) Reference voltage terminal, PS and PV are connected when shipping
 (2) +S & +V, -S & -V also need to be connected on CN1 or CN2.

4. Current Sharing

- Parallel operation is available by connecting the units shown as below (+S, -S and LS are connected mutually in parallel):
- The voltage difference among each output should be minimized that less than $\pm 2\%$ is required
- The total output current must not exceed the value determined by the following equation
 (Output current at parallel operation) = (The rated current per unit) x (Number of unit) x 0.9
- In parallel operation 3 units is the maximum, please consult the manufacturer for other applications
- When remote sensing is used in parallel operation, the sensing wire must be connected only to the master unit

Note: In parallel connection, maybe only one unit (master) operate if the total output load is less than 5% of rated load condition.
 The other PSUs (slaves) may go into standby mode and their output LEDs will not turn on.

